



mULTIDROP

TU INVENTA Y ELLA PRODUCE

ТЫ ПРИДУМЫВАЕШЬ, ОНА СОЗДАЕТ / VOCÊ CRIA, E ELA PRODUZ



PPOLIN®

MODELO

МОДЕЛИ / MODELOS

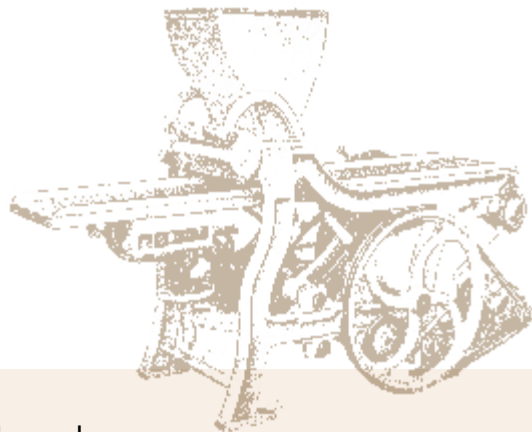

De siempre la Multidrop sirve a la pastelería de todo el mundo.

Los diversos modelos creados, Classic, Junior, están disponibles en una gama de versiones así de amplia para rendir perfecta para todo tipo de obrador de pastelería.

Los grandes maestros pasteleros de todo el mundo eligen Multidrop por que puede dar forma a sus ideas creativas y llegar al infinito con la máxima calidad.

Более 30 лет Multidrop обслуживает кондитеров по всему миру. Спроектированные модели Classic, Junior обогащены широкой гаммой версий, которая не оставляет за своими рамками ни одного запроса кондитерских цехов.

Самые великие мастера всего мира пользуются машиной Multidrop, потому что она способна воплотить в жизнь самые креативные идеи и реализовать их в массовом производстве.

A Multidrop sempre serviu confeitadores de todo o mundo. Os vários modelos projetados, Classic, Junior, estão disponíveis em uma variedade de versões tão grande que é perfeita para qualquer tipo de operação de confeitaria.

Os grandes mestres confeitadores do mundo escolhem a Multidrop porque se pode dar forma para as suas ideias mais criativas e repeti-las ao infinito com a mais alta qualidade.



CLASSIC TIPO C

CLASSIC NORMAL

CLASSIC FAST

JUNIOR



VERSIONES

ВЕРСИИ / VERSÕES

FCM
FCP

MESA FIJA
(regulable a mano)
СТОЛ НЕПОДВИЖНЫЙ
(ручная регулировка)
MESA FIXA
(regulável com a mão)

TROQUEL:
• FIJO

МАТРИЦА:
• С НЕПОДВИЖНЫМИ
НАСАДКАМИ

MOLDE:
• FIXO

FCC

MESA FIJA
(regulable a mano)
СТОЛ НЕПОДВИЖНЫЙ
(ручная регулировка)
MESA FIXA
(regulável com a mão)

TROQUEL:
• FIJO
• CORTE A HILO

МАТРИЦА:
• С НЕПОДВИЖНЫМИ
НАСАДКАМИ
• ДЛЯ СТРУННОЙ РЕЗКИ

MOLDE:
• FIXO
• CORTE À FIO

E
FE

TROQUEL:
• FIJO

МАТРИЦА:
• С НЕПОДВИЖНЫМИ
НАСАДКАМИ

MOLDE:
• FIXO

FET

TROQUEL:
• FIJO
• CORTE A HILO

МАТРИЦА:
• С НЕПОДВИЖНЫМИ
НАСАДКАМИ
• ДЛЯ СТРУННОЙ РЕЗКИ

MOLDE:
• FIXO
• CORTE À FIO

R
FR

TROQUEL:
• FIJO
• GIRATORIO

МАТРИЦА:
• С НЕПОДВИЖНЫМИ
НАСАДКАМИ
• С ВРАЩЕНИЕМ НАСАДОК

MOLDE:
• FIXE
• GIRATÓRIO

L
FL

TROQUEL:
• FIJO
• GIRATORIO
• CORTE A HILO

МАТРИЦА:
• С НЕПОДВИЖНЫМИ
НАСАДКАМИ
• С ВРАЩЕНИЕМ НАСАДОК
• ДЛЯ СТРУННОЙ РЕЗКИ

MOLDE:
• FIXO
• GIRATÓRIO
• CORTE À FIO

Troquel fijo / Матрица с неподвижными насадками / Molde fixo



Troquel giratorio / Матрица с вращением насадок / Molde giratório

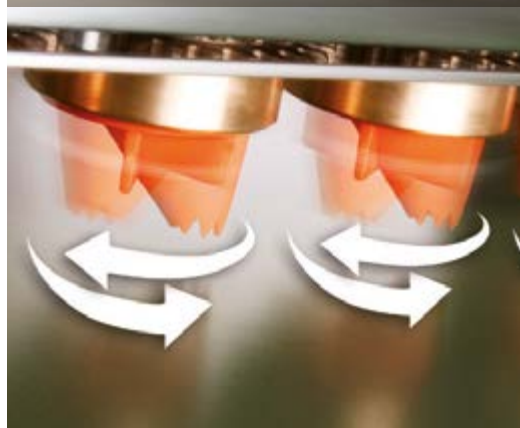

Corte a hilo / Матрица для струнной резки / Corte de fio



FXL

TROQUEL:

- FIJO
- GIRATORIO
- CORTE A HILO

МАТРИЦА:

- С НЕПОДВИЖНЫМИ НАСАДКАМИ
- С ВРАЩЕНИЕМ НАСАДОК
- ДЛЯ СТРУННОЙ РЕЗКИ

MOLDE:

- FIXO
- GIRATÓRIO
- CORTE À FIO



Multidrop en su máxima expresión.

Además de la posibilidad de los tres tipos de troquel, se añade un control del movimiento vertical de la mesa coordinado desde la computadora el trabajo de las boquillas. Se puede así crear todas las formas más fantásticas que se deseen, reproduciendo no solo el movimiento horizontal del "sac a poche" y también aquellos que sean verticales. Máxima libertad a la creatividad.

Multidrop в своем максимальном выражении.

К бесконечности реализаций благодаря трем типам матриц добавлена возможность контролировать с помощью компьютера движение стола вверх и вниз, синхронизируя стол с работой насадок. Таким образом, можно создавать самые необычные формы печенья, воспроизводя движение руки с «кулинарным мешком» как в горизонтальной, так и в вертикальной плоскостях, давая безграничную волю своей креативности.

Multidrop na sua máxima expressão.

Além das oportunidades dadas pelos três tipos de moldes, adicionamos o controle do movimento vertical da mesa em coordenação com os movimentos dos bicos, gerenciados pelo computador. Se pode criar todos os formatos mais criativos que você desejar, copiando não apenas os movimentos horizontais da "manga de confeitaria", mas também os verticais. Máxima liberdade à criatividade.

GESTION COMPUTARIZADA DEL MOVIMIENTO:

КОМПЬЮТЕРИЗИРОВАННОЕ УПРАВЛЕНИЕ ДВИЖЕНИЕМ: / GERENCIAMENTO COMPUTADORIZADO DE MOVIMENTO:

↕ MOVIMIENTO VERTICAL
ДВИЖЕНИЕ ПО ВЕРТИКАЛЬНОЙ ОСИ
MOVIMENTO VERTICAL

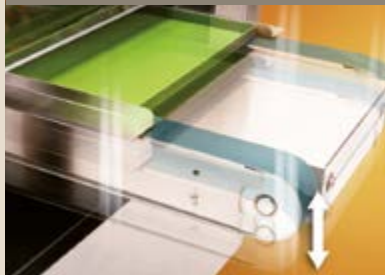

↔ MOVIMIENTO HORIZONTAL
ДВИЖЕНИЕ ПО ГОРИЗОНТАЛЬНОЙ ОСИ
MOVIMENTO HORIZONTAL



↻ MOVIMIENTO GIRATORIO
ВРАЩЕНИЕ
MOVIMENTO GIRATÓRIO



GRUPO DE DOSIFICACION Y TROQUELES

ГРУППЫ ДОЗИРОВКИ И ШТАМПЫ / GRUPO DE DOSAGEM E MOLDES

TOLVA / ОТСАДНЫЕ ГОЛОВКИ / САВЕЌОТЕ

A RODILLOS PARA MASA DURA / С ВАЛКОВОЙ СИСТЕМОЙ ДЛЯ ТВЕРДОГО ТЕСТА / POR ROLOS PARA MASSA DURA



Troquel fijo
Матрица с неподвижными насадками
Molde fixo



Troquel giratorio
Матрица с вращением
Molde giratório



Corte a hilo
Для струнной резки
Corte à fio



A RODILLOS CON ADAPTADOR PARA MASA BLANDA / С ВАЛКОВОЙ СИСТЕМОЙ С АДАПТЕРАМИ ДЛЯ ЖИДКОГО ТЕСТА / POR ROLOS COM ADAPTADORES LATERAIS PARA MASSA SEMI LÍQUIDA



Troquel fijo
Матрица с неподвижными насадками
Molde fixo



Troquel giratorio
Матрица с вращением
Molde giratório



A BOMBA PARA MASA BLANDA Y LIQUIDA / С ГОЛОВКОЙ НАСОСНОГО ТИПА ДЛЯ ЖИДКОСТИ И МЯГКОГО ТЕСТА / POR BOMBA PARA MASSAS LÍQUIDAS E MOLES

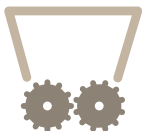

Troquel fijo
Матрица с неподвижными насадками
Molde fixo



Para bizcocho
Для бисквита
Para pão-de-ló



A BOMBA VOLUMETRICA / С ПОРШНЕВЫМ НАСОСОМ / POR BOMBA VOLUMÉTRICA

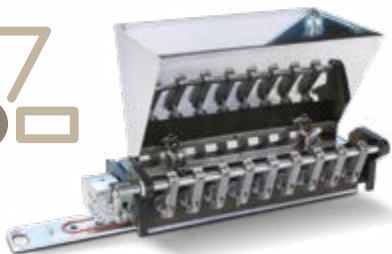

Troquel fijo
Матрица с неподвижными насадками
Molde fixo



CLASSIC TIPO C			CLASSIC NORMAL			CLASSIC FAST					JUNIOR				
FCP	FCM	FCC	E	R	L	FE	FET	FR	FL	FXL	FE	FET	FR	FL	FXL

•		•	•	•	•	•	•	•	•	•	•	•	•	•	•
					•	•			•	•				•	•
		•				•			•					•	•
•		•	•	•	•	•	•	•	•	•	•	•	•	•	•
					•	•			•	•				•	•
	•		•	•	•	•	•	•	•	•	•	•	•	•	•
	•		•	•	•	•	•	•	•	•	•	•	•	•	•
•	•	•	•	•	•	•	•	•	•	•	•	•	•	•	•

SOLO
 MODELO
 CLASSIC
 ТОЛЬКО ДЛЯ
 МОДЕЛЕЙ
 CLASSIC
 APENAS PARA
 O MODELO
 CLASSIC

DOTACION

ОБОРУДОВАНИЕ / EQUIPAMENTOS

TOLVA: ligera, ergonómica, fácilmente manejable para la operación de desmontaje y de lavado
CABEZAL A RODILLOS PARA MASA DURA: soporte de rodillos en aluminio endurecido y tratado, rodillos acanalados en acero inoxidable. Dotado de casquillo auto lubricado, en teflón, fácilmente sustituible.

CABEZAL A BOMBA PARA PASTA BLANDA: exterior del cabezal en aluminio endurecido y tratado, engranages. Dentados de la bomba en mezcla de diferentes metales.

CABEZAL A BOMBA VOLUMETRICA PARA PASTA BLANDA: modulo único en aluminio endurecido y tratado con cilindros en acero inoxidable independientes. La precisión del peso ha de ser perfecta aún incluyendo piezas de fruta, chocolate, frutos secos, etc.

ЗАГРУЗОЧНЫЕ ВОРОНКИ: Легкие, эргономичные, просты в уходе, демонтаже и промывке.

ВАЛКОВАЯ ГОЛОВКА ДЛЯ ТВЕРДОГО ТЕСТА: Основа валов из спец. закаленного и обработанного алюминия, рифленые валки из нержавеющей стали. Оснащена быстро и без труда заменяющимися самосмазывающимися тефлоновыми втулками.

ГОЛОВКА НАСОСНОГО ТИПА ДЛЯ МЯГКОГО ТЕСТА: Структура головки валов из спец. закаленного и обработанного алюминия, зубчатые шестерни насоса выполнены из металлического сплава.

ГОЛОВКА С ПОРШНЕВЫМ НАСОСОМ: Моноблок из спец. закаленного и обработанного алюминия с независимыми цилиндрами из нержавеющей стали. Служит для стабильного и точного дозирования теста с добавками (например, кусочками фруктов, шоколада, орешек).

TACHO: leve, ergonômico, fácil de manusear, desmontar e limpar.

CABEÇOTE DOS ROLOS PARA MASSA DURA: bordas de alumínio reforçadas, rolos com ranhuras em aço inoxidável. Equipados com buchas de teflon autolubrificantes, fáceis de substituir.

CABEÇOTE À BOMBA PARA MASSA MOLE: Exterior do cabeçote em alumínio fundido, engrenagens dentadas em liga de bronze para uso alimentar.

CABEÇOTE À BOMBA VOLUMÉTRICA PARA MASSA MOLE: Monobloco de alumínio fundido com cilindros independentes em aço inoxidável. Para dosar as massas líquidas, como bolos e muffins, sem alterar as suas características originais e manter o peso preciso mesmo com pedaços de frutas.

Cabezal a rodillos para masa dura
Головка валкового типа для твердого теста
Cabeçote por rolos para massa dura



Cabezal a bomba para masa blanda
Головка насосного типа для мягкого теста
Cabeçote à bomba para massa mole



Cabezal a bomba volumétrica
Головка с поршневым насосом
Cabeçote à bomba volumétrica



CONTROL COMPLETO

ПОЛНОЕ АВТОМАТИЧЕСКОЕ УПРАВЛЕНИЕ / CONTROLE COMPLETO

TODO MAS FACIL CON EL TOUCH DISPLAY

Multidrop dotada de un software potente y desarrollado, que permite memorizar todas las recetas que quieran. El programa, completo pero simplificado al máximo, permite controlar con gran precisión cada función da la maquina.

ВСЕ НАМНОГО ПРОЩЕ С СЕНСОРНЫМ ЭКРАНОМ

Мощное современное программное обеспечение Multidrop позволяет создавать и запоминать всевозможные рецепты. Программа, упрощенная для пользователей, позволяет с огромной точностью контролировать любую функцию машины.

TUDO É MAIS FÁCIL COM A TELA DE TOQUE

Multidrop é equipado com um software avançado e poderoso, que permite armazenar todas as receitas que você deseja. O programa abrangente, porém muito simplificado, permite o controle com alta precisão de cada função da máquina.



TOMA USB

ВЫХОД USB / PORTA USB

Para el Down load del menú memorizado, y el archivo de parámetros de funcionamiento.

Для копирования меню, сохранения рабочих параметров.

Para fazer download dos menus armazenados, e arquivo de parâmetros de funcionamento.

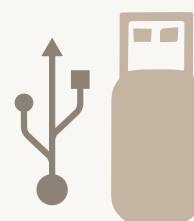

DESCUBRE LA GRAN GAMA DE PRODUCTOS!

ОТКРОЙ ДЛЯ СЕБЯ ВСЮ ГАММУ ПРОДУКЦИИ!
DESCUBRA NOSSA GRANDE VARIEDADE DE PRODUTOS!

Troquel inyección crema
Дюзы для ввода крема
Molde de injeção de creme



Filler block
Дозировочный блок
Bloco de recheio

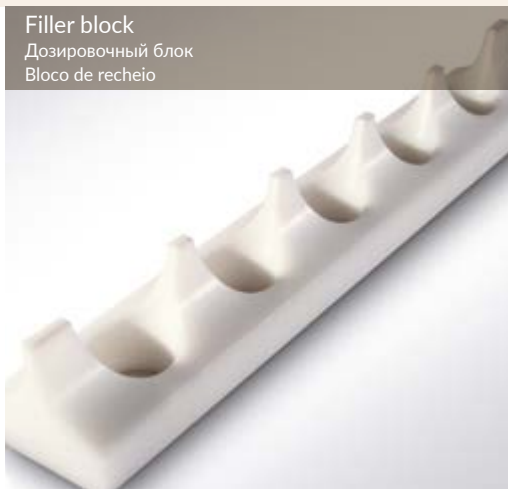

Cinta
Ремни
Correia



JUNIOR
FE
FET
FR
FL
FXL

FAST
FE
FET
FR
FL
FXL

NORMAL
E
R
L



CABEZAL CON RODILLOS PARA MASA DURA*

Boquillas y troqueles de corte a hilo pueden ser fabricados según su solicitud

ВАЛКОВАЯ ГОЛОВКА ДЛЯ ТВЕРДОГО ТЕСТА

По заказу могут быть созданы индивидуальные, не входящие в данный каталог, фильеры для струнной резки

CABEÇÓTE COM ROLOS PARA MASSA DURA

Bicos e moldes de corte à fio podem ser produzidos sob encomenda

TROQUEL FIJO / МАТРИЦА С НЕПОДВИЖНЫМИ НАСАДКАМИ / MOLDE FIXO



P7



P8



P9



DR10



DR45



M22



M46



M60



M59



M61



M469



M450



M451



M452

FXL



M453 ⇕



M454 ⇕



M455 ⇕ ⇔



M456 ⇕ ⇔

*NO JUNIOR

Movimiento / Движение / Movimento: ⇕ ⇔



TROQUEL FIJO / МАТРИЦА С НЕПОДВИЖНЫМИ НАСАДКАМИ / MOLDE FIXO



P4



M32



DR33



DR34



M62



M63



M64



M457



M458

FXL



M459 ⇕



M460 ⇕



M461 ⇕ ↔



M462 ⇕ ↔

*NO JUNIOR

Movimiento / Движение / Movimento: ⇕ ↔

JUNIOR
FE
FET
FR
FL
FXL

FAST
FE
FET
FR
FL
FXL

NORMAL
E
R
L



TROQUEL FIJO / МАТРИЦА С НЕПОДВИЖНЫМИ НАСАДКАМИ / MOLDE FIXO

JUNIOR
FE
FET
FR
FL
FXL

FAST
FE
FET
FR
FL
FXL

NORMAL
E
R
L



P1 rizada/рельфная/estriada



P1 lisa/гладкая/lisa



P2 rizada/рельфная/estriada



P2 lisa/гладкая/lisa



P6 rizada/рельфная/estriada



P6 lisa/гладкая/lisa



P14 rizada derecha/рельфная справа/estriada direita
P14 rizada izquierda/рельфная слева/estriada esquerda



P14 lisa, derecha/гладкая справа/lisa direita
P14 lisa, izquierda/гладкая слева/lisa esquerda



P18 izquierda/справа/esquerda
P18 derecha/слева/direita



P5



M75



M76



TROQUEL FIJO / МАТРИЦА С НЕПОДВИЖНЫМИ НАСАДКАМИ / MOLDE FIXO



M77



M78



M79



M80



M81



M82



M83



M84



M85



M86



M88 rizada/рельфная/estriada



M88 lisa/гладкая/lisa



JUNIOR
FE
FET
FR
FL
FXL

FAST
FE
FET
FR
FL
FXL

NORMAL
E
R
L



TROQUEL FIJO / МАТРИЦА С НЕПОДВИЖНЫМИ НАСАДКАМИ / MOLDE FIXO

JUNIOR
FE
FET
FR
FL
FXL

FAST
FE
FET
FR
FL
FXL

NORMAL
E
R
L



M89



M90



M302



M303



M304



M305



M306



M87



M313



M314



M402A



M404A



TROQUEL GIRATORIO / МАТРИЦА С ВРАЩЕНИЕМ НАСАДОК / MOLDE GIRATÓRIO



P13



M65



M66



M67



M68



M69



M70



M463



M464



M465



M466

JUNIOR
FR
FL
FXL

FAST
FR
FL
FXL

NORMAL
R
L



JUNIOR
FR
FL
FXL

FAST
FR
FL
FXL

NORMAL
R
L



TROQUEL GIRATORIO / МАТРИЦА С ВРАЩЕНИЕМ НАСАДОК / MOLDE GIRATÓRIO



M467



M15



M71



M468

TROQUEL GIRATORIO / МАТРИЦА С ВРАЩЕНИЕМ НАСАДОК / MOLDE GIRATÓRIO



DR52



M469



M72

FXL



M470 ↕ ↻



M471 ↕ ↻



M472 ↔ ↻

*NO JUNIOR

Movimiento / Движение / Movimento: ↕ ↔ ↻

CORTE A HILO / МАТРИЦЫ СТРУННОЙ РЕЗКИ / CORTE À FIO

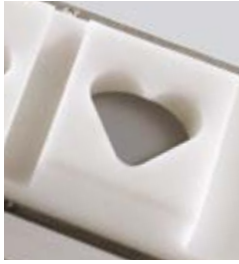

DR27



DR41



M100



M101



M102



M103



M130



M131



M133



M134



M135



M136



M193



M192



JUNIOR
FET
FL
FXL

FAST
FET
FL
FXL

NORMAL
L

TIPO C
FCC



CORTE A HILO / МАТРИЦЫ СТРУННОЙ РЕЗКИ / CORTE À FIO

CORTE A HILO / МАТРИЦЫ СТРУННОЙ РЕЗКИ / CORTE À FIO

JUNIOR
FET
FL
FXL

FAST
FET
FL
FXL

NORMAL
L

TIPO C
FCC



M137



M138



M139



M140



M144



M145



M146



M148



M149



M155



M159



M160



M603



M604



CORTE A HILO / МАТРИЦЫ СТРУННОЙ РЕЗКИ / CORTE À FIO

CORTE A HILO / МАТРИЦЫ СТРУННОЙ РЕЗКИ / CORTE À FIO



M161



M163



M164



M165



M166

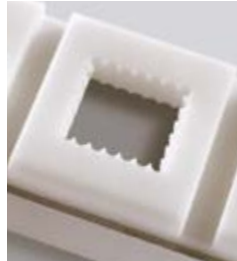

M167

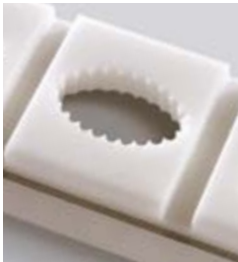

M168



M169

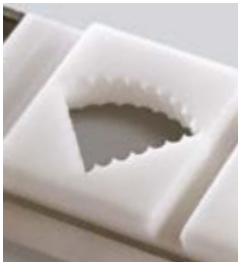

M170



M171



M172



M173



M174



M175



JUNIOR
FET
FL
FXL

FAST
FET
FL
FXL

NORMAL
L

TIPO C
FCC



CORTE A HILO / МАТРИЦЫ СТРУННОЙ РЕЗКИ / CORTE À FIO

CORTE A HILO / МАТРИЦЫ СТРУННОЙ РЕЗКИ / CORTE À FIO

JUNIOR
FET
FL
FXL

FAST
FET
FL
FXL

NORMAL
L

TIPO C
FCC



M180



DR36



DR58 (Ø40)



DR58 (Ø40)



DR25 (Ø50)



DR25 (Ø50)



Y ACOPLANDOSE ENTRE ELLAS LA FORMAS OBTENIDAS ILIMITADAS SOLUCIONES CREATIVAS...
 .. А, КОМБИНИРУЯ НЕСКОЛЬКО ФОРМ, МОЖНО СОЗДАТЬ НЕОГРАНИЧЕННОЕ КОЛИЧЕСТВО КРЕАТИВНЫХ МОДЕЛЕЙ...
 SE VOCÊ COMBINAR AS FORMAS JUNTAS, VOCÊ PODE OBTER SOLUÇÕES CRIATIVAS INFINITAS...

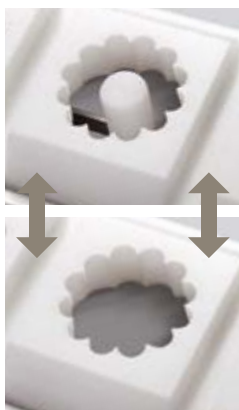

Combinación/Комбинирующая/Combinação
DR58 (Ø40)

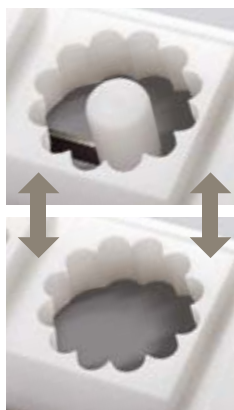

Combinación/Комбинирующая/Combinação
DR25 (Ø50)



CORTE A HILO / МАТРИЦЫ СТРУННОЙ РЕЗКИ / CORTE À FIO

DESCUBRE TODAS
LAS OTRAS FORMAS

ОТКРОЙ ДЛЯ СЕБЯ
ДРУГИЕ ФОРМЫ

DESCUBRA TODOS
OS OUTROS FORMATOS



WWW.MULTIDROP.IT





CABEZAL A RODILLOS CON ADAPTADOR PARA MASA BLANDA*

Boquillas y troqueles de corte a hilo pueden ser fabricados según su solicitud

ВАЛКОВАЯ ГОЛОВКА С АДАПТЕРАМИ ДЛЯ ЖИДКОГО ТЕСТА
По заказу могут быть созданы индивидуальные, не входящие в данный каталог, фильеры для струнной резки.

CABEÇÓTE POR ROLOS COM ADAPTADORES LATERAIS PARA MASSA SEMI LÍQUIDA
Bicos e moldes de corte à fio podem ser produzidos sob encomenda

JUNIOR
FE
FET
FR
FL
FXL

FAST
FE
FET
FR
FL
FXL

NORMAL
E
R
L

TIPO C
FCP
FCC



TROQUEL FIJO / МАТРИЦА С НЕПОДВИЖНЫМИ НАСАДКАМИ / MOLDE FIXO



P3



P27



P28



P29



P30



P19



M28



M38



M104



M473

JUNIOR
FE
FET
FR
FL
FXL

FAST
FE
FET
FR
FL
FXL

NORMAL
E
R
L

TIPO C
FCP
FCC



M105



M106



M107



M108



M109



M110

FXL



M200 ⇕



M201 ⇕



M202 ⇕



M203 ⇕



M204 ⇕



M205 ⇕



M474 ⇕



M475 ⇕



M476 ⇕



*NO JUNIOR

M477 ⇕ ⇔



M478 ⇕ ⇔

Movimiento / Движение / Movimento: ⇕ ⇔

TROQUEL FIJO / МАТРИЦА С НЕПОДВИЖНЫМИ НАСАДКАМИ / MOLDE FIXO



P10



M111



M112



M479

JUNIOR
FE
FET
FR
FL
FXL

FAST
FE
FET
FR
FL
FXL

NORMAL
E
R
L



FXL



M206 ↔



M207 ↔



M208 ⇅



M211 ⇅ ↔



M480 ⇅ ↔

*NO JUNIOR



M481 ⇅



*NO JUNIOR

M482 ⇅ ↔



M483 ⇅

Movimiento / Движение / Movimento: ⇅ ↔

TROQUEL GIRATORIO / МАТРИЦА С ВРАЩЕНИЕМ НАСАДОК / MOLDE GIRATÓRIO

JUNIOR
FE
FET
FR
FL
FXL

FAST
FE
FET
FR
FL
FXL

NORMAL
E
R
L



M12



M484



M113



M116



M114



M117



M115

FXL



M209 ⇕ ⌚



M210 ⇕ ⌚



M485 ⇕ ⌚



M486 ⇕ ⌚ ⇔



M487 ⇕ ⌚ ⇔



M488 ⇕ ⌚ ⇔

Movimiento / Движение / Movimento: ⇕ ⇔ ⌚



TROQUEL GIRATORIO / МАТРИЦА С ВРАЩЕНИЕМ НАСАДОК / MOLDE GIRATÓRIO

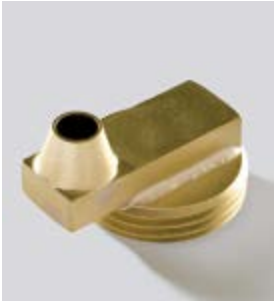

M121



M489

JUNIOR
FR
FL
FXL

FAST
FR
FL
FXL

NORMAL
R
L



FXL



M212 ⇕ ⌚



M214 ⇕ ⌚



M213 ⇕ ⌚



M490 ⇕ ⌚



*NO JUNIOR

M491 ⇕ ⌚

Movimiento / Движение / Movimento: ⇕ ⇔ ⌚

TROQUEL GIRATORIO / МАТРИЦА С ВРАЩЕНИЕМ НАСАДОК / MOLDE GIRATÓRIO

JUNIOR
FR
FL
FXL

FAST
FR
FL
FXL

NORMAL
R
L



P11



M118



M119



M120



M122



M494

FXL



M215 ⇕ ⌚



M216 ⇕ ⌚



M217 ⇕ ⌚



M218 ⇕ ⌚



M495 ⇔ ⌚

*NO JUNIOR

Movimiento / Движение / Movimento: ⇕ ⇔ ⌚



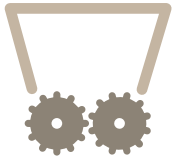

A BOMBA E A BOMBA VOLUMETRICA PARA MASA BLANDA*

Boquillas y troqueles de corte a hilo pueden ser fabricados según su solicitud

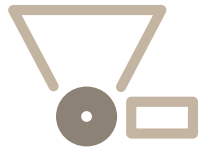

ГОЛОВКА НАСОСНОГО ТИПА И ГОЛОВКА С ПОРШНЕВЫМ НАСОСОМ ДЛЯ МЯГКОГО ТЕСТА
По заказу могут быть созданы индивидуальные, не входящие в данный каталог,
фильеры для струнной резки

САВЕЌÓТЕ À BOMBA E À BOMBA VOLUMÉTRICA PARA MASSA MOLE
Bicos e moldes de corte à fio podem ser produzidos sob encomenda

JUNIOR
FE
FET
FR
FL
FXL

FAST
FE
FET
FR
FL
FXL

NORMAL
E
R
L

TIPO C
FCM



TROQUEL FIJO / МАТРИЦА С НЕПОДВИЖНЫМИ НАСАДКАМИ / MOLDE FIXO



P20



M496



P21



M497



M498



P49



P25



M126

JUNIOR
FE
FET
FR
FL
FXL

FAST
FE
FET
FR
FL
FXL

NORMAL
E
R
L

TIPO C
FCM



M499



P23



M17



M123



M124



M125



P37



M127

TROQUEL PARA BIZCOCHO / МАТРИЦА ДЛЯ БИСКВИТА / MOLDE PARA PÃO-DE-LÓ



M4

CARACTERÍSTICAS TÉCNICAS

ТЕХНИЧЕСКИЕ ХАРАКТЕРИСТИКИ / CARACTERÍSTICAS TÉCNICAS

JUNIOR

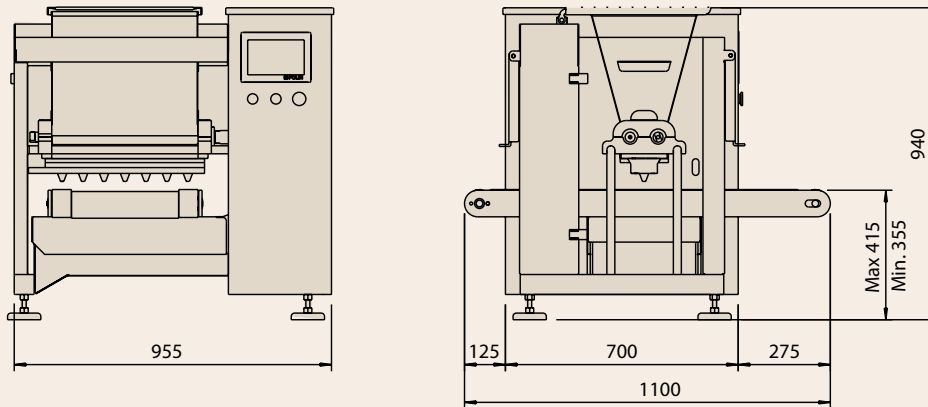

	DIMENSION DE LA BANDEJA РАЗМЕРЫ ЛИСТА TAMANHO DAS BANDEJAS		DATOS TECNICOS ТЕХНИЧЕСКИЕ ДАННЫЕ CARACTERÍSTICAS TÉCNICAS					PRESTACIONES ПРОИЗВОДИТЕЛЬНОСТЬ DESEMPENHO		DIMENSIONES Y PESOS РАЗМЕРЫ И ВЕС DIMENSÕES E PESO	
	Ancho Ширина Largura mm	Largo Длина Comprimento mm	Tensión Напряжение Tensão Volt	Potencia Мощность Potência kW	Peso Вес Peso Kg	Capaci- dad Объем Capacidade l	Sonoridad Шум Nível de ruído dB (A)	Depositado Отсадка Pingado (max cicl- cycles/1')	Corte a hilo Струнная резка Corte à fio (max cicl- cycles/1')	Embalaje Упаковка Embalagem	
										mm	Kg
FE	400-460	400-700	400/3N~/50	1,1	190	35	<70	20	-	1300 1200 h. 1250	260
FET	400-460	400-700	400/3N~/50	1,1	200	35	<70	20	30	1300 1200 h. 1250	270
FR	400-460	400-700	400/3N~/50	1,3	200	35	<70	20	-	1300 1200 h. 1250	270
FL	400-460	400-700	400/3N~/50	1,3	210	35	<70	20	30	1300 1200 h. 1250	280
FXL	400-460	400-700	400/3N~/50	1,3	220	35	<70	20	30	1300 1200 h. 1250	290

CLASSIC TIPO C

CLASSIC NORMAL

CLASSIC FAST

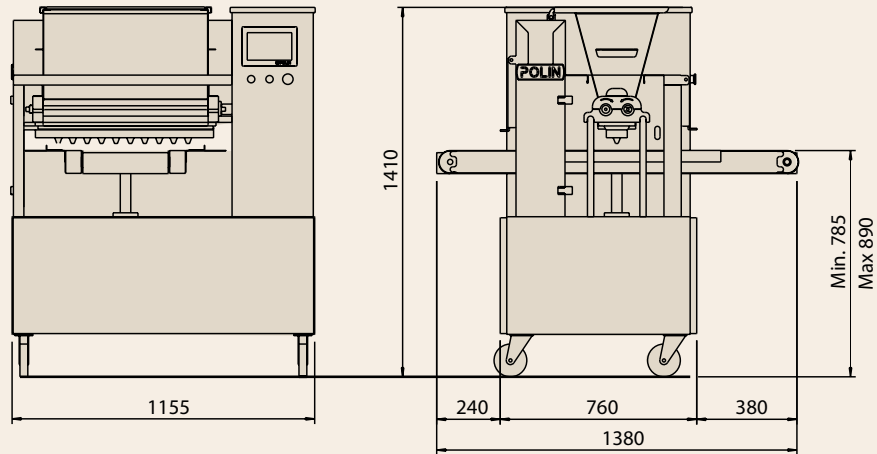

	DIMENSION DE LA BANDEJA РАЗМЕРЫ ЛИСТА TAMANHO DAS BANDEJAS		DATOS TECNICOS ТЕХНИЧЕСКИЕ ДАННЫЕ CARACTERÍSTICAS TÉCNICAS					PRESTACIONES ПРОИЗВОДИТЕЛЬНОСТЬ DESEMPENHO		DIMENSIONES Y PESOS РАЗМЕРЫ И ВЕС DIMENSÕES E PESO		
	Ancho Ширина Largura mm	Largo Длина Comprimento mm	Tensión Напряжение Tensão Volt	Potencia Мощность Potência kW	Peso Вес Peso Kg	Capacidad Объем Capacidade l	Sonoridad Шум Nível de ruído dB (A)	Depositado Отсадка Pingado (max ciclos/1')	Corte a hilo Струнная резка Corte à fio (max ciclos/1')	Embalaje Упаковка Embalagem		
										mm	Kg	
CLASSIC TIPO C	FCP	400-460	400-800	400/3N~/50	0,6	235	35	<70	20	-	1550	350
		600-660				240	50				h. 1600	355
	FCM	400-460	400-800	400/3N~/50	0,6	240	35	<70	20	-	1550	355
		600-660				245	50				h. 1600	360
FCC	400-460	400-800	400/3N~/50	0,6	240	35	<70	20	30	1550	355	
	600-660				245	50				h. 1600	360	
CLASSIC NORMAL	E	400-460	400-800	400/3N~/50	1,6	300	35	<70	20	-	1550	450
		600-660				305	50				h. 1600	455
	R	400-460	400-800	400/3N~/50	1,9	310	35	<70	20	-	1550	460
		600-660				315	50				h. 1600	465
	L	400-460	400-800	400/3N~/50	1,9	320	35	<70	20	30	1550	470
		600-660				325	50				h. 1600	475
CLASSIC FAST	FE	400-460	400-800	400/3N~/50	1,7	300	35	<70	26	-	1550	450
		600-660				305	50				h. 1600	455
	FET	400-460	400-800	400/3N~/50	1,7	310	35	<70	26	35	1550	460
		600-660				315	50				h. 1600	465
	FR	400-460	400-800	400/3N~/50	2,0	310	35	<70	26	-	1550	460
		600-660				315	50				h. 1600	465
	FL	400-460	400-800	400/3N~/50	2,0	320	35	<70	26	35	1550	470
		600-660				325	50				h. 1600	475
FXL	400-460	400-800	400/3N~/50	2,1	325	35	<70	26	35	1550	475	
	600-660				330	50				h. 1600	480	

CARACTERÍSTICAS / ХАРАКТЕРИСТИКИ / CARACTERÍSTICAS

Ancho del cabezal
 Estructura en acero inoxidable y ruedas giratorias con freno
 Mesa fácil y rápidamente desmontable
 Facilidad de montaje y lavado del cabezal
 Cabezal con rodillos e acero inoxidable con adaptadores para masa blanda
 Touch screen con display TFT a colores 7"
 Declaración de conformidad normas CE
 Posibilidad de montar cabezales diferentes en base a los productos
 Rotación de rodillos con velocidad variable electrónicamente
 Dispositivo de rotación de las boquillas
 Dispositivo de corte a hilo
 Avance automático de la bandeja con velocidad variable electrónicamente
 Motor de avance de la bandeja para otras prestaciones
 Posicionamiento de la mesa motorizada
 Posicionamiento de la mesa motorizado y automático
 Back&Forth Drive System

JUNIOR	CLASSIC NORMAL	CLASSIC FAST	CLASSIC TIPO C
40-46	40-46-60-66	40-46-60-66	40-46-60-66
solo opcional con carro	●	●	●
●	●	●	●
●	●	●	●
●	●	●	●
●	●	●	●
●	●	●	●
●	●	●	●
FR - FL - FXL	R - L	FR - FL - FXL	
FET - FL - FXL	L	FET - FL - FXL	FCC
●	●		
		●	●
●	●		
FXL		FXL	

Ширина головки
 Рама из нержавеющей стали, с колесиками и тормозами
 Стол просто и быстро разбирается
 Простота ухода и установки головки
 Головка с вальками из нержавеющей стали с адапторами для жидкого теста
 Цветной сенсорный экран на 7"
 Сертификат соответствия CE, EAC
 Возможность установить разные головки в зависимости от продукта
 Двигатель вращения валков с частотным преобразователем
 Двигатель вращения насадок с частотным преобразователем
 Система струнной резки
 Двигатель автоматического прохода листа с частотным преобразователем
 Высокоэффективный двигатель прохода листов
 Позиционирование стола по вертикальной оси с моторизацией
 Автоматическое позиционирование стола по вертикальной оси с моторизацией
 Back Forth Drive System

40-46	40-46-60-66	40-46-60-66	40-46-60-66
Только опция с тележкой	●	●	●
●	●	●	●
●	●	●	●
●	●	●	●
●	●	●	●
●	●	●	●
●	●	●	●
FR - FL - FXL	R - L	FR - FL - FXL	
FET - FL - FXL	L	FET - FL - FXL	FCC
●	●		
		●	●
●	●		
FXL		FXL	

Largura do cabeçote
 Estrutura em aço inoxidável e rodas giratórias com freio
 Mesa de fácil e rápida desmontagem
 Cabeçote de fácil limpeza e desmontagem
 Cabeçote com rolos em aço inoxidável com adaptadores para pastas moles
 Tela sensível ao toque com display TFT colorido de 7 polegadas
 Declaração de conformidade norma CE
 É possível utilizar diferentes cabeçotes de acordo com os produtos
 Rotação dos rolos com velocidade variável eletronicamente
 Dispositivo de rotação dos bicos
 Dispositivo de corte à fio
 Avanço automático da bandeja com velocidade variável eletronicamente
 Motor de avanço da bandeja para outras operações
 Posicionamento da mesa motorizado
 Posicionamento da mesa automático e motorizado
 Sistema de Acionamento Back&Forth

40-46	40-46-60-66	40-46-60-66	40-46-60-66
opcional apenas com carro	●	●	●
●	●	●	●
●	●	●	●
●	●	●	●
●	●	●	●
●	●	●	●
●	●	●	●
FR - FL - FXL	R - L	FR - FL - FXL	
FET - FL - FXL	L	FET - FL - FXL	FCC
●	●		
		●	●
●	●		
FXL		FXL	

* Decoraciones, guarniciones y acoplamiento estan hechos a mano / El *savoirdi* son depositados en bandeja troquelada / Madelanas y plum cakes son depositados en bandeja troquelada

Декорации, начинки и комбинации разных форм делаются вручную / Савойарды отсаживаются на листы с предусмотренными формами / Магдалены и кексы отсаживаются на листы с предусмотренными формами

Decorações, coberturas e combinações são feitas à mão / Biscoitos são pingados em bandejas com moldes / Madelanas e bolos são pingados em bandejas com moldes

Desde 1929 líder en el mundo del Arte Bianca

Representamos la mas grande realidad industrial italiana en la fabricación de hornos y de maquinas para el Pan, para pastelería y pastas.

Realizamos enteramente la mas completa gama de alta calidad "para el moderno Obrador de Arte Bianca". Hace mas de noventa y cinco año que llevamos por todo el mundo la gran prestación de tecnología resultado de nuestro ingenio.

С 1929 г лидер в мире «Arte Bianca - Белого Искусства»

На территории Италии мы являемся самым крупным производственным концерном, создающим профессиональное оборудование для производства печенье, печи, кондитерские и хлебопекарные линии.

Производимый нами ассортимент оборудования полностью воплощает в жизнь современные лаборатории в мире «Arte Bianca - Белого Искусства». Более 90 лет мы распространяем по всему миру наилучшие современные технологические решения изобретенной нами продукции.

Desde 1929 líder mundial na Arte Branca

Nós representamos o maior mercado industrial italiano na fabricação de fornos e máquinas para pães, confeitos e massas. Nós produzimos a maior e mais completa variedade de alta qualidade para o moderno laboratório da "Arte da Branca". Por mais de 90 anos, introduzimos importantes inovações tecnológicas em todo o mundo, fruto de nossa engenharia.



Ing. Polin e C. S.p.A.

Viale dell'Industria, 9 - 37135 Verona - Italy - Tel. +39 045 8289111 - Fax +39 045 8289122

polin@polin.it - www.polin.it

