

WRAPPING

V-PACK 2 CFU/CDU

multistyle wrapping machines
for small chocolate eggs and balls



V-PACK 2 CFU/CDU
speed up to 800 ppm

models

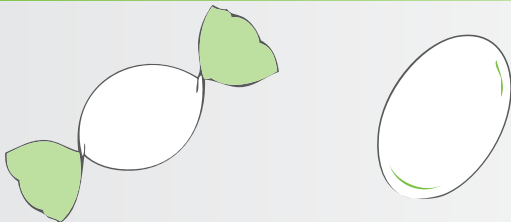

standard features

MULTISTYLE high speed wrapping machine for round shaped pralines (small eggs and balls) in double twist and fancy rolled wrapping style with single or double wrapping materials. The machine is equipped with a vibrating hopper and disk to optimize product feeding.

- MULTISTYLE concept thanks to machine MODULARITY
- Suitable for all kind of processed pralines ENROBED, MOULDED, etc.
- Style and/or format CHANGE OVER TIME: less than 45 minutes
- HMI by color graphic Touch Screen
- Possible upgrade with extra wrapping style modules at customer site
- Rolling unit for fancy style
- Servo-driven Paper feeding / No Product - No Paper system
- Gently and positively handling of product and wrapping material
- Product always under operator control during both the feeding and the wrapping sequence
- Good accessibility, easy cleaning, maintenance and size change-over operations

optionals

- Automatic splicer for outer & /or inner wrapping material
- Spliced product reject device
- Cold seal for "Protected Double Twist"

technical data

V-PACK 2 CFU/CDU

total weight	3000 Kg
total installed power	8,5 Kw
supply pressure average consumption	6 bar 450 NI/min
paint	RAL 7035 Gloss 80

product size range

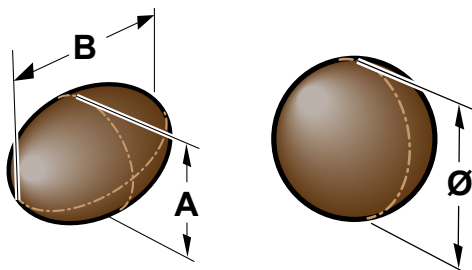

mm	A	B	Ø
min	14	18	14
max	30	30	30

Dimension next or beyond the limits of the above range to be evaluated.

layout

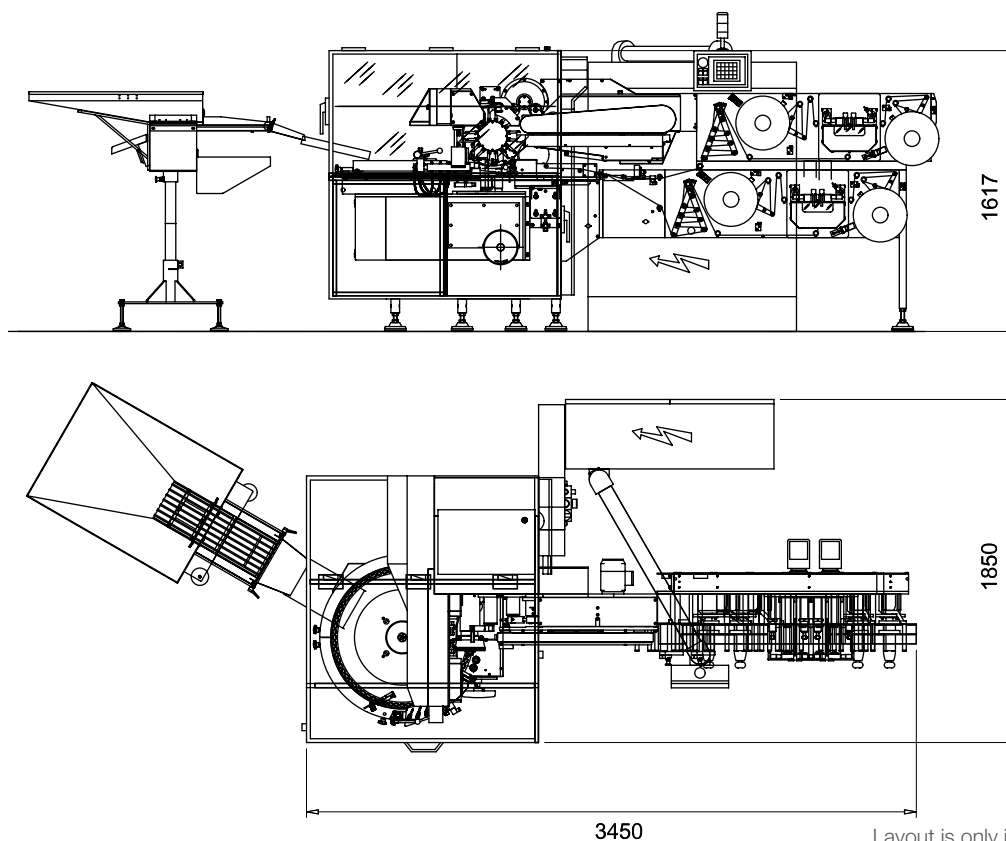

Layout is only indicative.

