

**WRAPPING**

**V-PACK 2 CD/CB4/B**

multistyle wrapping machines  
for flat-base chocolate pralines



<b>models</b>	<p><b>V-PACK2 CD / CB4 / B</b> speed up to 650 ppm</p>
<b>standard features</b>	<p>Multistyle high-speed belt feeding modular wrapping machine for flat-base pralines suitable for the most common wrapping styles. The machine can be equipped with an automatic aligner to optimize product feeding.</p> <ul style="list-style-type: none"> <li>● MULTI STYLE concept thanks to the machine MODULARITY</li> <li>● Suitable for all kinds of processed pralines: ENROBED, MOULDED, EXTRUDED, DEPOSITED, etc.</li> <li>● Style and/or format CHANGE OVER TIME: less than 45 minutes</li> <li>● HMI by color graphic Touch Screen</li> <li>● Possible upgrade with extra wrapping style modules even at customer site</li> <li>● Servo-driven paper feeding system</li> <li>● No Product-No Paper device</li> <li>● Gentle and positive handling of product and wrapping material</li> <li>● Product always under operator control both during feeding and wrapping sequences</li> <li>● Good accessibility, easy cleaning, maintenance and size change-over operations</li> </ul>
	<b>optionals</b>

technical data

V-PACK2 CD / CB4 / B	
total weight	3000 Kg
total installed power	8,5 Kw
supply pressure   average consumption	6 bar   450 NI/min
paint	RAL 7035 Gloss 80

product size range

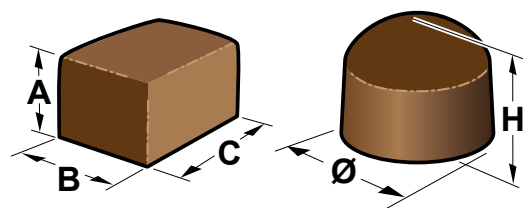

mm	A	B	C	Ø	H
min	5	18	25	12	22
max	25	35	60	28	35

Dimension next or beyond the limits of the above range to be evaluated.

layout

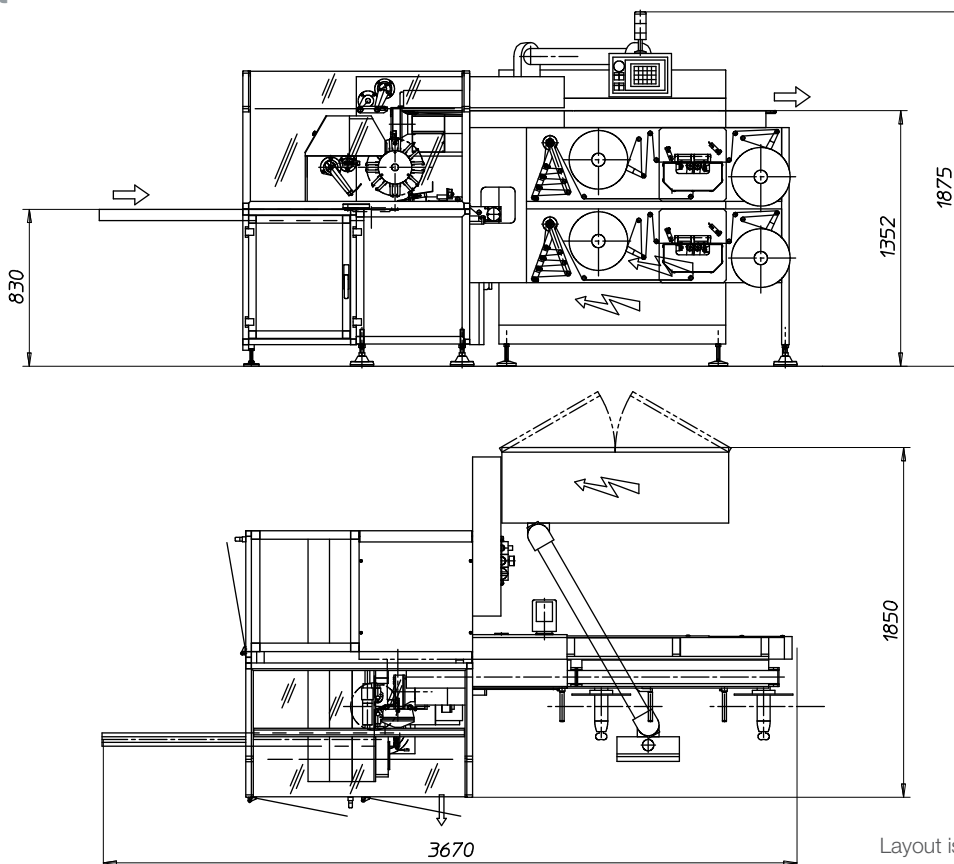

Layout is only indicative.

