

SECONDARY PACKAGING

WA series

Wrap-Around machines



The WA series consists of wrap-around automatic machines for products, packaged by wrapping machines or side loading machines, in fluted corrugated paperboard and /or trays.

The trays can be rectangular, with walls having either the same height or different heights.

The WA is suitable for creating boxes of different sizes with the same framework.

The blank magazine contains all the blanks and its capacity can be increased through modular expanding unit.

The WA machines can achieve an output up to 30 packs per minute, depending on size of the box and products.

Optionals to equip the WA according to different box closing options (flat base box or tray + lid configuration) are available.

For lower productions, the WA machines can be equipped also with, when it's possible, pneumatic controls. Changeover could be manual or automatic.

Moreover, all the WA machines are equipped with a single or double in-line infeed or at 90° and preparation of the box according to customer's needs.

STANDARD FEATURES

Modularity => a lot of possible configurations using the same framework

Ergonomics of the blanks dispenser => Easy blank loading & fast changeover

Integrated electric panel => Reduced amount of space & easy accessibility from all sides

High performances => High quality of the operations also at high speeds

Multi - styles of boxes and cartons => Possibility to serve several formats

Flat base box configuration

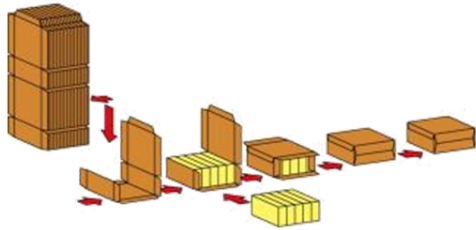
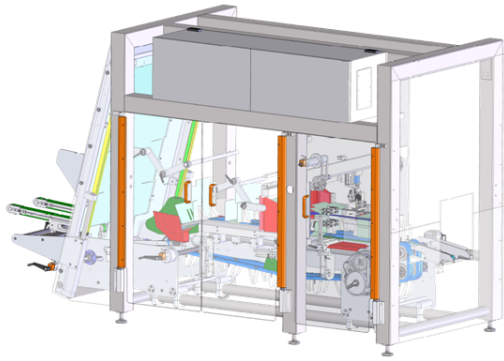

PITCH 609,6 mm: 20 cartons per minute

PITCH 457,2 mm: 25 cartons per minute

PITCH 304,8 mm: 30 cartons per minute

Tray + lid configuration

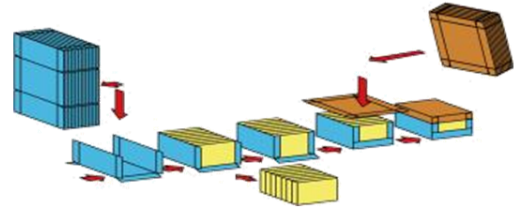
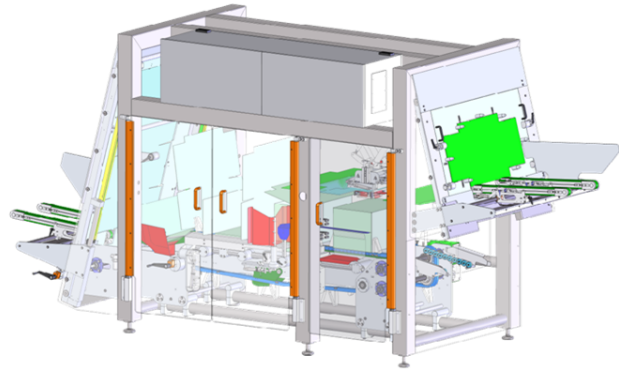

LAYOUTS

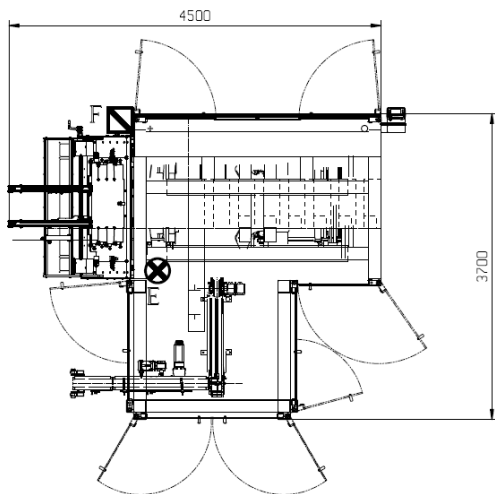
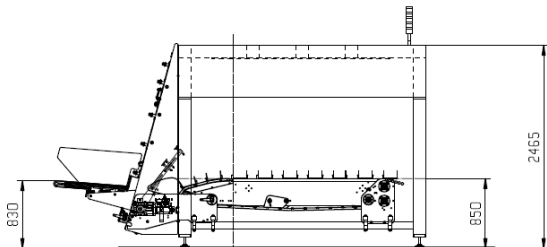

Example of layout for flat base box configuration

