

# COCOA PROCESSING

## POV Horizontal Cocoa Presses



**POV 590/16**

### STANDARD FEATURES

**All the main components of these presses (cylinders, head, columns, pots and counter-pots) are made of mechanically machined forged steel.**

**The special design of both pots and counter-pots gives them a great resistance to high pressure and, consequently, a high strain strength.**

**All components are designed and assembled so as to allow an easy cleaning of the press and achieve a high degree of hygiene.**

**The new technology employed for the construction of the pots and counter-pots made it possible to reduce the number of components, thus lowering the maintenance costs.**

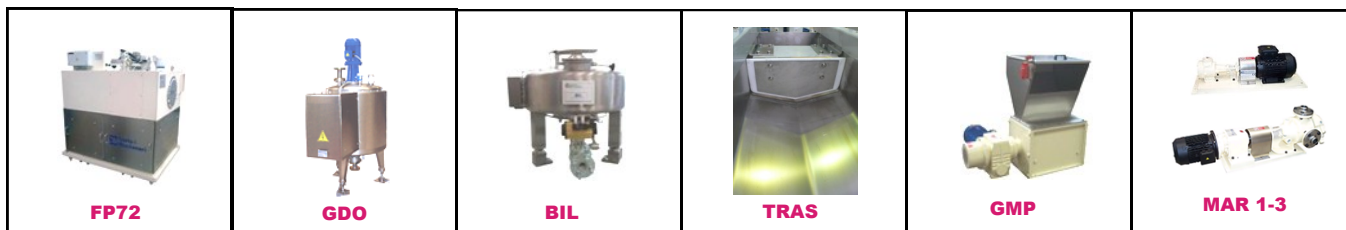
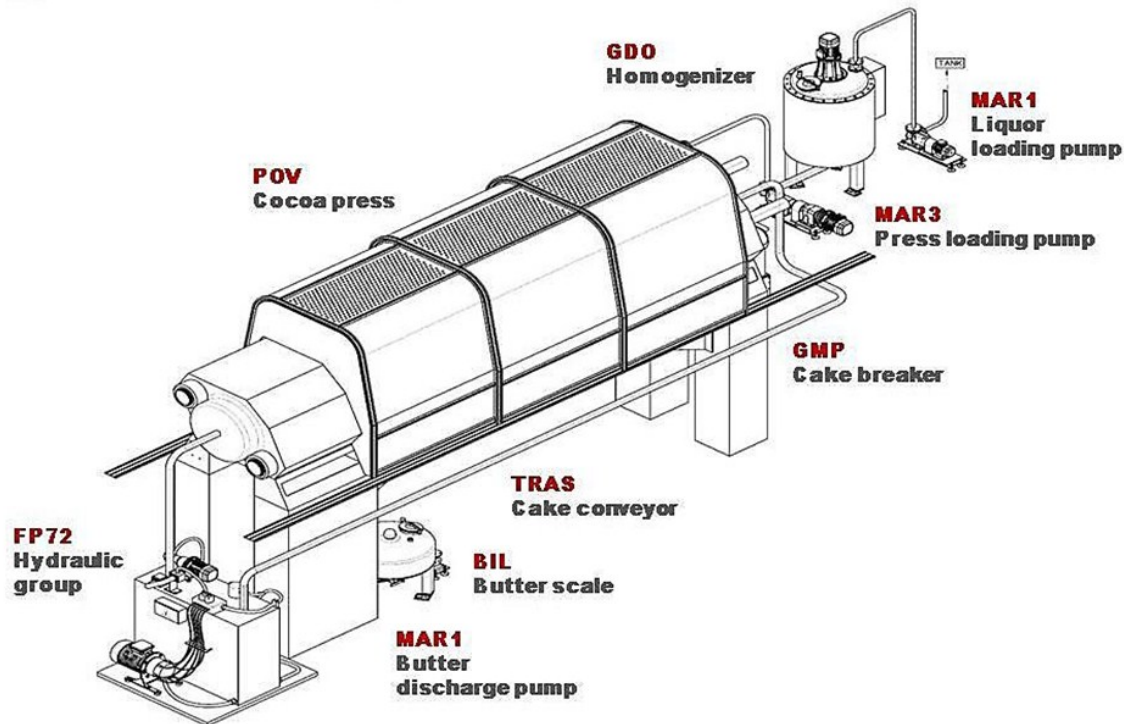

## TECHNICAL DATA

|                               | POV/540          | POV/540 | POV/540 | POV/540 | POV/540 | POV/590 |
|-------------------------------|------------------|---------|---------|---------|---------|---------|
|                               | 6                | 10      | 12      | 14      | 16      | 16      |
| <b>Pots (n)</b>               | 6                | 10      | 12      | 14      | 16      | 16      |
| <b>Loading capacity (l)</b>   | 78               | 130     | 156     | 182     | 208     | 236     |
| <b>Pot diameter (mm)</b>      | 423              | 423     | 423     | 423     | 423     | 450     |
| <b>Piston diameter (mm)</b>   | 540              | 540     | 540     | 540     | 540     | 590     |
| <b>Max pressure (bar)</b>     | 550              | 550     | 550     | 550     | 550     | 550     |
| <b>Length (mm)</b>            | 4.100            | 5.400   | 6.300   | 7.200   | 7.850   | 8.000   |
| <b>Width (mm)</b>             | 1.600            | 1.600   | 1.600   | 1.600   | 1.600   | 1.700   |
| <b>Height (mm)</b>            | 1.700            | 1.700   | 1.700   | 1.700   | 1.700   | 1.900   |
| <b>Total weight (kg)</b>      | 14.000           | 27.000  | 30.000  | 34.000  | 36.000  | 42.000  |
| <b>Pressing cycles (n/h)</b>  | up to 5 per hour |         |         |         |         |         |
| <b>Hourly capacity (kg/h)</b> | 425              | 715     | 855     | 1.000   | 1.140   | 1.300   |

Indicative productivity values are referred to cocoa liquor and subject to variations according to the characteristics of the mass and the residual butter in the cake.