

# SECONDARY PACKAGING

## F-EL Electronic box forming machine

**One of the most compact and reliable vertical box erector on the market for hot melt glued boxes:**

- One, two and three forming heads
- Compact design
- Highly reliable
- Quick changeover



### MAIN OPTIONS

- Blank magazine with side loading and active pressure control system, 900 mm long, adjustable in width and height by hand-wheels with position indicator
- Blank extraction system from the magazine with servo-drive, pick-up arm with suction cups
- Blank transferring system with mechanical “positive” and servo-drive
- Blank plunger with vertical movement and servo-drive, easily exchangeable
- Female format with adjustable rollers for box folding and sealing, fitted on a manually easily exchangeable frame
- Automatic hot-melt dispenser, completed with hoses and spraying guns, fitted on adjustable supports with position indicators
- Automatic downstream backlog control (empty boxes)
- Alluminium frame, with floor levelling feet
- Openable safety guards made of transparent polycarbonate
- On-board electrical cabinet equipped with PLC
- MMI touch panel interface for recipe selection, fault display and parameter editing

## BLANKS DIMENSIONS

BLANKS DIMENSIONS FEL-S1 SINGLE FORMAT						
	A	B	C	D	E	F
max.	750	600	200	1190	1000	200
min.	200	100	25	180	100	25
	G	H	I	L	M	N
max.	1190	1000	200	750	600	200
min.	200	100	25	180	50	25

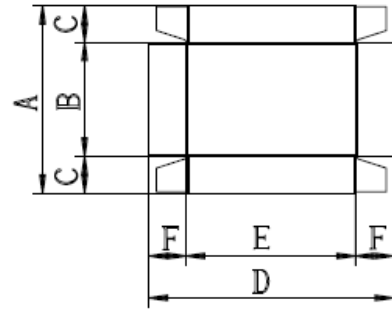

BLANKS DIMENSIONS FEL-D2 DOUBLE FORMAT						
	A	B	C	D	E	F
max.	750	600	200	550	370	200
min.	200	100	25	180	100	25
	G	H	I	L	M	N
max.	550	370	200	750	600	200
min.	200	100	25	180	50	25

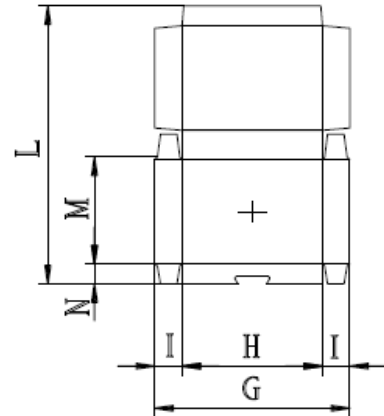

## LAYOUT

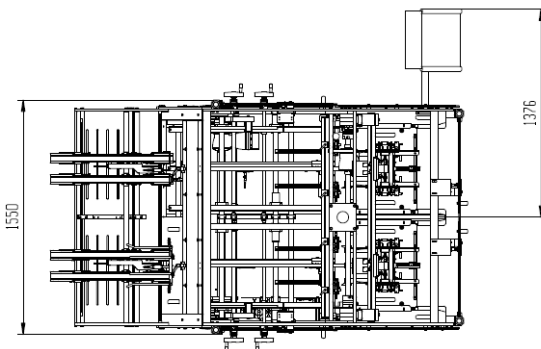
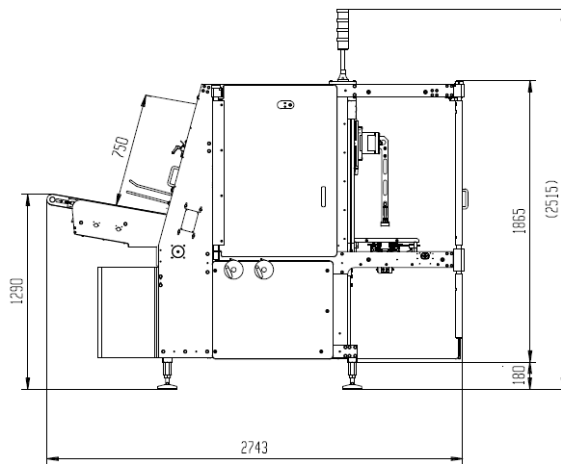

**MAX 60 cycle/1'**

