

PRIMARY PACKAGING

EWF

Row feeders for automatic flow-wrappers

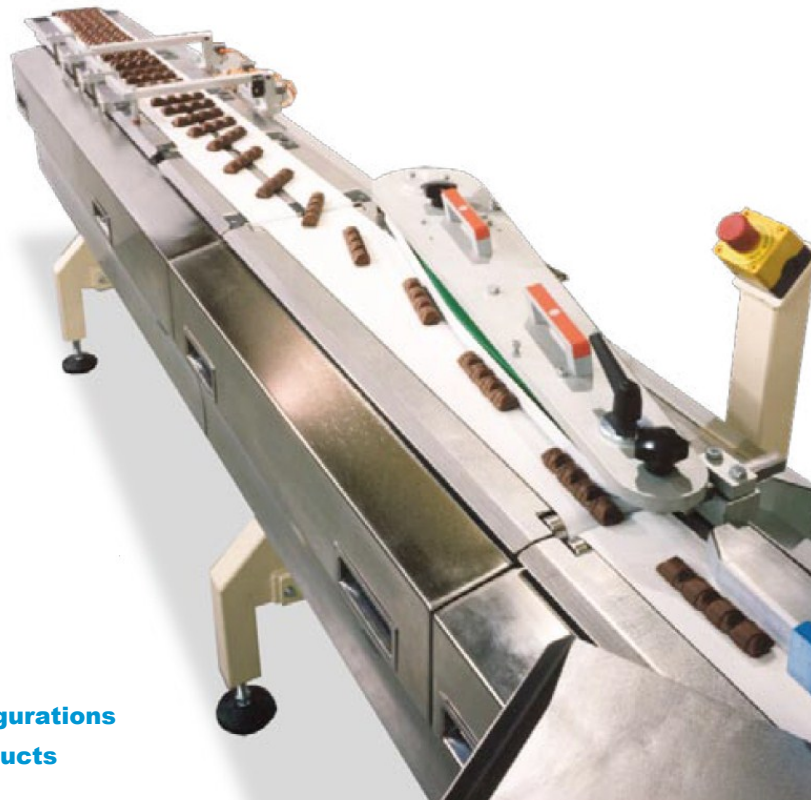

- **Hygienic design**
- **Completely servo-driven**
- **Easy maintenance**
- **Custom and special configurations available for difficult products**

Belt groups controlled by an independent Servo Motor in full coordination with the flow-wrapper

- **Available in right-hand and left-hand versions**
- **Able to guarantee maximum precision and a smooth transfer while keeping the design as simple as possible**
- **Modular units for row gap closing, product rotation and orientation, metal-checking, collecting/phasing products available**

STANDARD FEATURES

- **Cantilevered execution**
- **All parts in contact with the products are in stainless steel**
- **Safety and Electrical norms according to CE standards.**
- **Various solutions available (In-line, 110°, Chicanes, Wheel feeders,...)**
- **Low contact or zero contact units available**
- **Tool-less conveyor belt replacement**

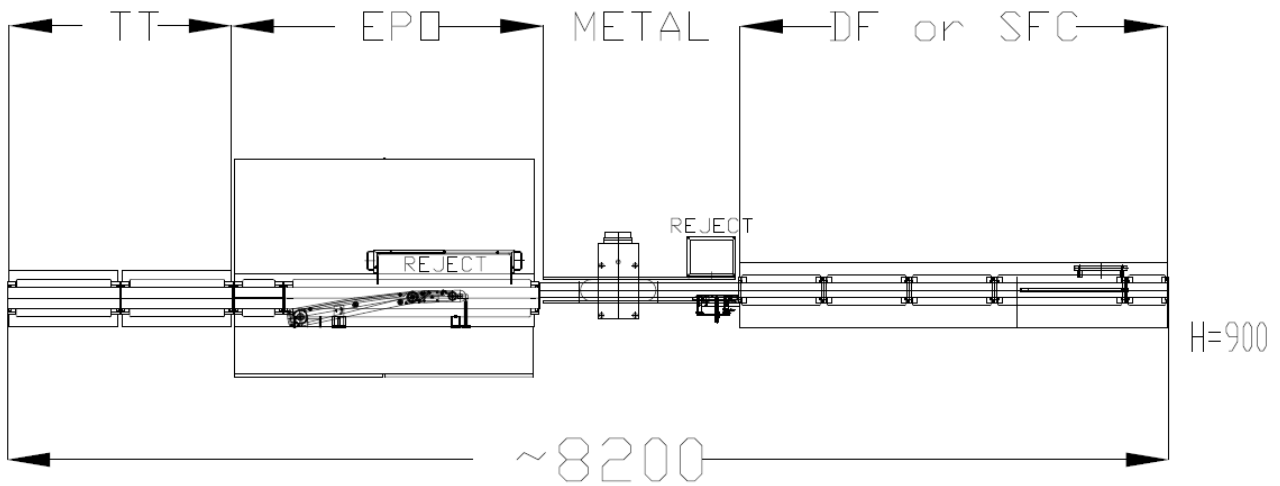

OPTIONALS

- Cardboard feeder
- Metal detector
- Overhead belt(s) for additional control of the products
- Vacuum system
- Liquid cooled product plates (open and closed circuits available)

